

3500/45 Position Monitor

Datasheet

Bently Nevada Machinery Condition Monitoring

141537 Rev. L

Description

The 3500/45 Position Monitor is a 4-channel instrument that accepts input from proximity transducers, Rotary Position Transducers (RPTs), DC Linear Variable Differential Transformers (DC LVDTs), AC Linear Variable Differential Transformers (AC LVDTs), and rotary potentiometers. The monitor conditions the input and compares the conditioned signals with user-programmable alarms.



The type of measurement and transducer input determine which I/O modules are required. [See Transducer Types for Position Measurements on page 11.](#), [See Figures and Graphs on page 14.](#), and [See I/O Modules for AC LVDTs and Rotary Potentiometers on page 16.](#)

You can program each channel using the 3500 Rack Configuration Software to perform the following functions:

- Axial (thrust) Position
- Differential Expansion
- Standard Single Ramp Differential Expansion
- Non-standard Single Ramp Differential Expansion
- Dual Ramp Differential Expansion
- Complementary Differential Expansion
- Case Expansion
- Valve Position



The monitor channels are programmed in pairs and can perform up to two of these functions at a time. For example, Channels 1 and 2 can perform





one function while channels 3 and 4 may perform the same or a different function.

The primary purpose of the 3500/45 Position Monitor is to provide the following:

- Machinery protection by continuously comparing monitored parameters against configured alarm setpoints to drive alarms
- Essential machine information for operations and maintenance personnel

Each channel, depending on configuration, typically conditions its input signal to generate various parameters called **measured variables**. You can establish **alert setpoints** for each active measured variable and **danger setpoints** for any two of the active measured variables.

Specifications

Inputs

Signal	Accepts from 1 to 4 signal inputs
Power consumption	7.7 watts, typical, using Position I/O, or 8.5 watts typical, using AC LVDT I/O or 5.6 watts typical, using Rotary Potentiometer I/O
Input Impedance	1 MΩ (DC LVDT inputs) 10 kΩ (Proximitor or RPT inputs) 137 kΩ (AC LVDT inputs) 200 kΩ (Rotary Potentiometer inputs)

Sensitivity

Thrust	3.94 mV/μm (100 mV/mil) or 7.87 mV/μm (200 mV/mil)
Differential Expansion	0.394 mV/μm (10 mV/mil) or 0.787 mV/μm (20 mV/mil)
Ramp Differential Expansion	0.394 V/mm (10 mV/mil), 0.787 V/mm (20 mV/mil), 3.937 V/mm (100 mV/mil), or 7.874 V/mm (200 mV/mil)
Complementary Input Differential Expansion	0.394 V/mm (10 mV/mil), 0.787 V/mm (20 mV/mil), or 3.937 V/mm (100 mV/mil)
DC LVDT Case Expansion	0.05 V/mm (1.25 V/in), 0.08 V/mm (1.90 V/in), 0.10 V/mm (2.50 V/in), 0.18 V/mm (4.50 V/in), 0.20 V/mm (5.00 V/in), or 0.22 V/mm (5.70 V/in)

AC LVDT Case Expansion	28.74 mV/V/mm (0.73 mV/V/mil), 15.35 mV/V/mm (0.39 mV/V/mil), or 9.45 mV/V/mm (0.24 mV/V/mil)
AC LVDT Valve Position	28.74 mV/V/mm (0.73 mV/V/mil) 15.35 mV/V/mm (0.39 mV/V/mil), 9.45 mV/V/mm (0.24 mV/V/mil), 10.24 mV/V/mm (0.26 mV/V/mil), 7.48 mV/V/mm (0.19 mV/V/mil), 5.51 mV/V/mm (0.14 mV/V/mil), 3.94 mV/V/mm (0.10 mV/V/mil), or 3.15 mV/V/mm (0.08 mV/V/mil)
Rotary Potentiometer Valve Position	41 mV/degree rotation
Rotary Position Transducer (RPT) Valve Position	140 mV/deg rotation, 70 mV/deg rotation, or 50 mV/deg rotation

Outputs

Front Panel LEDs	
OK LED	Indicates when the 3500/45 Position Monitor is operating properly.
TX/RX LED	Indicates when the 3500/45 Position Monitor is communicating with other modules in the 3500 rack.
Bypass LED	Indicates when the 3500/45 Position Monitor is in Bypass Mode.

Transducer Power Supply

Proximator or RPT	-24 Vdc
DC LVDT	+15 Vdc
AC LVDT	2.3Vrms 3400Hz sine wave
Rotary Potentiometer	-12.38 Vdc
Recorder	+4 to +20 mA Values are proportional to monitor full-scale. The monitor provides individual recorder values for each channel except Ramp and CIDE. Monitor operation is unaffected by short circuits on recorder outputs.
Voltage Compliance (current output)	0 to +12 Vdc range across load Load resistance is 0 to 600 Ω.
Resolution	0.3662 μA per bit ±0.25% error at room temperature ±0.7% error over temperature range Update rate 100 ms or less

Signal Conditioning



Specified at +25 °C (+77 °F) unless otherwise noted.

Thrust and Differential Expansion

Accuracy	Within ±0.33% of full-scale typical ±1% maximum
----------	--

Frequency Response

Direct filter	-3 dB at 1.2 Hz
Gap filter	-3 dB at 0.41 Hz

Ramp Differential Expansion

Accuracy	See Ramp Differential Expansion Accuracy on page 13.
----------	--

Frequency Response

Direct filter	-3 dB at 1.2 Hz
Gap filter	-3 dB at 0.41 Hz

Complimentary Input Differential Expansion (CIDE)

Accuracy	Within ±0.33% of full-scale typical ±1% maximum
----------	--

Frequency Response

Direct filter	-3 dB at 1.2 Hz
Gap filter	-3 dB at 0.41 Hz

Case Expansion

Accuracy	Within ±0.33% of full-scale typical ±1% maximum
----------	--

Frequency Response

Direct filter	-3 dB at 1.2 Hz
Gap filter	-3 dB at 0.41 Hz

Valve Position

Accuracy	Within $\pm 0.33\%$ of full-scale typical $\pm 1\%$ maximum
----------	--

Frequency Response

Direct filter	-3 dB at 1.2 Hz
Gap filter	-3 dB at 0.41 Hz

Physical

Monitor Module (Main Board)

Dimensions (Height x Width x Depth)	241.3 mm x 24.4 mm x 241.8 mm (9.50 in x 0.96 in x 9.52 in)
Weight	0.91 kg (2.0 lb)

I/O Modules

Dimensions (Height x Width x Depth)	241.3 mm x 24.4 mm x 99.1 mm (9.50 in x 0.96 in x 3.90 in)
Weight	0.20 kg (0.44 lb)

Rack Space Requirements

Monitor Module	1 full-height front slot
I/O Modules	1 full-height rear slot

Alarms

	Use the 3500 Rack Configuration Software to set alert and danger levels for the direct values measured by the monitor.
Alarm Setpoints	Alarms are adjustable from 0 to 100% of full-scale for each measured value. However, when the full-scale range exceeds the range of the transducer, the range of the transducer will limit the setpoint.
Accuracy of alarm setpoints	Within 0.13% of the desired value

Alarm Time Delays



You can program alarm delays using the 3500 Rack Configuration Software from one to 60 seconds in one second intervals.

Alert	From one to 60 seconds in one second intervals
Danger	0.1 seconds or from one to 60 seconds in 0.1 second intervals

Measured Variables



Position measurements are used for machine protection and condition monitoring. The 3500/45 Position Monitor returns values for the following measured variables depending on configuration.

Thrust Position	Direct Gap
-----------------	---------------

Differential expansion	Direct Gap
Ramp Differential Expansion	Composite Direct Gap
CIDE	Composite Direct Gap
Case expansion	Composite Direct and position
Value position	Direct and position

Environmental Limits

Operating Temperature	When used with Internal/External Termination I/O Module: -30°C to +65°C (-22°F to +150°F)
Storage Temperature	-40°C to +85°C (-40°F to +185°F)
Humidity	95% Non-condensing

Firmware and Software Requirements

When adding the 3500/45 Position Monitor to an existing 3500 system, the following firmware and software versions or later are required:

- 3500/20 RIM Firmware rev. G
- 3500 Configuration Software 2.41
- 3500 Data Acquisition 2.20
- 3500 Operator Display 1.20
- 3500/93 Display Interface Module 135799-01
- Firmware rev. G
- For Valve Position using RPT, you must have 3500 Configuration Software 3.00 or greater.

Compliance and Certifications (Approvals Pending)

FCC

This device complies with part 15 of the FCC Rules. Operation is subject to the following two conditions:

- This device may not cause harmful interference.
- This device must accept any interference received, including interference that may cause undesired operation.

EMC

European Community Directive:

EMC Directive 2014/30/EU

Standards:

EN 61000-6-2; Immunity for Industrial Environments
EN 61000-6-4; Emissions for Industrial Environments

Electrical Safety

European Community Directive:

LV Directive 2014/35/EU

Standards:

EN 61010-1

RoHS

European Community Directive:

RoHS Directive 2011/65/EU

Maritime

DNV GL rules for classification – Ships, offshore units, and high speed and light craft

ABS Rules for Condition of Classification, Part 1

- Steel Vessels Rules
- Offshore Units and Structures

Hazardous Area Approvals



For the detailed listing of country and product specific approvals, refer to the *Approvals Quick Reference Guide* (108M1756) available from Bently.com.

cNRTLus

Class I, Zone 2: AEx/Ex nA nC ic IIC T4 Gc;
Class I, Zone 2: AEx/Ex ec nC ic IIC T4 Gc;
Class I, Division 2, Groups A, B, C, and D;

T4 @ Ta= -20°C to +65°C (-4°F to +149°F)
When installed per drawing 149243 or 149244.

ATEX/IECEX

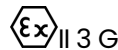

Ex nA nC ic IIC T4 Gc
Ex ec nC ic IIC T4 Gc

T4 @ Ta= -20°C to +65°C
(-4°F to +149°F)
When installed per drawing 149243 or 149244.

Ordering Information



For the detailed listing of country and product specific approvals, refer to the *Approvals Quick Reference Guide* (108M1756) available from Bently.com.

Position Monitor 3500/45 - AA-BB

A: I/O Module Type

01	Position I/O Module with Internal Terminations (Proximitor, RPT, DC LVDT)
02	Position I/O Module with External Terminations (Proximitor, RPT, DC LVDT)
03	Discrete TMR Position I/O Module with External Terminations (Proximitor or DC LVDT)
04	Bussed TMR Position I/O Module with External Terminations (Proximitor)
05	AC LVDT Position I/O Module with Internal Terminations
06	AC LVDT Position I/O Module with External Terminations

B: Agency Approval

00	None
01	cNRTLus (Class 1, Division 2)
02	ATEX / IECEx / CSA (Class 1, Zone 2)

You must order external termination blocks and cables separately for each I/O module with external termination.

When using the 3500/45 Position Monitor in a TMR application, valve position measurement are not available, and case expansion measurements are only supported for Discrete TMR.

External Termination Blocks

132242-01	Prox/Seismic TMR I/O Bussed External Termination Block (Euro-style connectors) for Proximitor inputs
132234-01	TMR I/O Busses External Termination Block Terminal Strip connectors
125808-06	Position External Termination Block (Euro-style connectors) for Proximitor, RPT and DC LVDT inputs
128015-06	Position External Termination Block (Terminal Strip connectors) for Proximitor, RPT and DC LVDT inputs
141208-01	AC LVDT External Termination Block (Euro-style connectors) for AC LVDT inputs
141216-01	AC LVDT External Termination Block (Terminal Strip connectors) for AC LVDT inputs
128702-01	Recorder External Termination Block (Euro-style connectors)
128710-01	Recorder External Termination Block (Terminal Strip connectors)

Cables

3500 Transducer (XDCR) to External Termination (ET) Block Cable 129525 - AAAA-BB

A: I/O Cable Length	
0005	5 feet (1.5 metres)
0007	7 feet (2.1 metres)
0010	10 feet (3.0 metres)
0025	25 feet (7.6 metres)
0050	50 feet (15.2 metres)
0100	100 feet (30.5 metres)
B: Assembly Instructions	
01	Not assembled
02	Assembled

3500 Recorder Output to External Termination (ET) Block Cable 129529 - AAAA-BB

A: I/O Cable Length	
0005	5 feet (1.5 metres)
0007	7 feet (2.1 metres)
0010	10 feet (3.0 metres)
0025	25 feet (7.6 metres)
0050	50 feet (15.2 metres)
0100	100 feet (30.5 metres)
B: Assembly Instructions	
01	Not assembled
02	Assembled

Spares

176449-04	3500/45 Position Monitor
135137-01	Position I/O Module with Internal Terminations for use with Proximitors, RPTs or DC LVDTs
135145-01	Position I/O Module with External Terminations for use with Proximitors, RPTs or DC LVDTs
139554-01	AC LVDT Position I/O Module with Internal Terminations for use with AC LVDTs
139567-01	AC LVDT Position I/O Module with External Terminations for use with AC LVDTs
139991-01	Rotary Potentiometer Position I/O Module with External Terminations for use with Rotary Potentiometers
125808-06	Position-Prox/DC LVDT - Euro
141208-01	Position-Prox/AC LVDT - Euro
132242-01	Prox/Seis TMR ET Block - Euro
128702-01	Recorder ET Block - Euro
128015-06	Position External Termination Block (Terminal Strip connectors) for Proximitor, RPT and DC LVDT inputs

141216-01	AC LVDT External Termination Block (Terminal Strip connectors) for AC LVDT inputs
132234-01	TMR I/O Busses External Termination Block Terminal Strip connectors
128710-01	Recorder External Termination Block (Terminal Strip connectors)
166M4363	Connector Header Push-in-Spring Type (Alternative for PN 00580441)
166M2389	Connector Header Push-in-Spring Type (Alternative for PN 00580434)
166M2388	Connector Header Push-in-Spring Type (Alternative for PN 00580432)
166M2379	Connector Header Push-in-Spring Type (Alternative for PN 00580443)

Transducer Types for Position Measurements

The following table lists transducer types for each position measurement:

Measurement	Transducer Type	
Thrust	Proximitys	
	3300XL 8 mm 3300 8 mm 3300 5 mm 3300 16 mm HTPS 7200 5 mm 7200 8 mm	7200 11 mm 3300XL 11mm 7200 14 mm 3000 (-18V) 3000 (-24V) 3300 RAM
Differential Expansion	Proximitys	
	25 mm Extended Range 35 mm Extended Range 50 mm Extended Range	
Ramp Differential Expansion	Proximitys For Ramp and Flat Channels	Proximitys For Flat Channel
	3300XL 11mm 7200 11 mm 7200 14 mm 3300 16 mm HTPS 25 mm Extended Range 35 mm Extended Range 50 mm Extended Range 50 mm DE Transducer	3300XL 8 mm 3300 8 mm 7200 5 mm 7200 8 mm
Complementary Input Differential Expansion	Proximitys	
	3300XL 11mm 7200 11 mm 7200 14 mm 3300 16 mm HTPS 25 mm Extended Range	35 mm Extended Range 50 mm Extended Range 50 mm DE Transducer
Case Expansion (Channels 3 and 4 only)	DC LVDTs	AC LVDTs
	25 mm (1 in) 50 mm (2 in) 101 mm (4 in)	25 mm (1 in) 50 mm (2 in) 101 mm (4 in)

Measurement	Transducer Type		
Valve Position	AC LVDTs	Rotary Potentiometer	Rotary Position Transducer
	25 mm (1 in) 50 mm (2 in) 101 mm (4 in) 152 mm (6 in) 203 mm (8 in) 254 mm (10 in) 304 mm (12 in) 508 mm (20 in)	50° FS rotation to 300° FS rotation	100° FS 200° FS 300° FS

Ramp Differential Expansion Accuracy

Maximum Tolerance in Percent of Full-Scale	Channel Pair Type and Configuration Parameters		
	Standard Single Ramp Differential Expansion	Nonstandard Signal Ramp Differential Expansion	Dual Ramp Differential Expansion
±1.0	Ramp angles 4 - 45 degrees Greater than 3 Vdc full-scale span Same model transducers on each channel	Ramp angles 4 - 70 degrees Greater than 3 Vdc full-scale span	Ramp angles 4 - 70 degrees Greater than 3 Vdc full-scale span
±1.25	Ramp angles 4 - 70 degrees Greater than 3 Vdc full-scale span Same model transducer on both channels	N/A	N/A
±1.5	Ramp angles 4 - 70 degrees Greater than 3 Vdc full-scale span Different model transducer on each channel	N/A	N/A
±2.0	Ramp angles 4 - 70 degrees Less than 3 Vdc full-scale span Same or Different model transducer on each channel	Ramp angles 4 - 70 degree Less than 3 Vdc full-scale span	Ramp angles 4 - 70 degrees Less than 3 Vdc full-scale span

Figures and Graphs

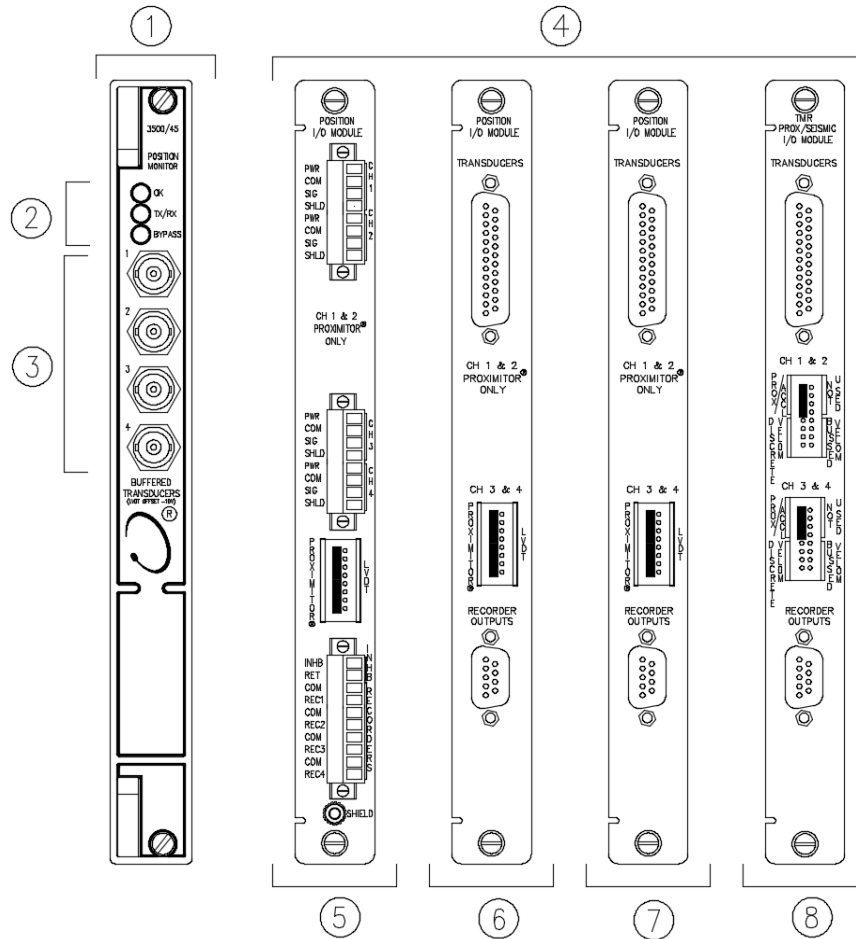

1. Front View of 3500/45 Position Monitor
2. Status LEDs
3. Buffered Transducer Outputs
4. Rear Views of I/O Modules with Proximitors, Rotary Position Transducers or DC LVDTs.
5. Position I/O Module, Internal Termination, for Use with Proximitors, Rotary Position Transducers, or DC LVDTs
6. Position I/O Module, External Termination, for Use with Proximitors, Rotary Position Transducers, or DC LVDTs
7. Position I/O Module, TMR Discrete, External Termination, for Use with Proximitors or DC LVDTs
8. Prox/Seismic I/O Module, TMR Bussed, External Termination for Use with Proximitors

Figure 1: Front and Rear Views of 3500/45 Position Monitor and I/O modules for use with Proximitor, Rotary Position Transducer and DC LVDT I/Os

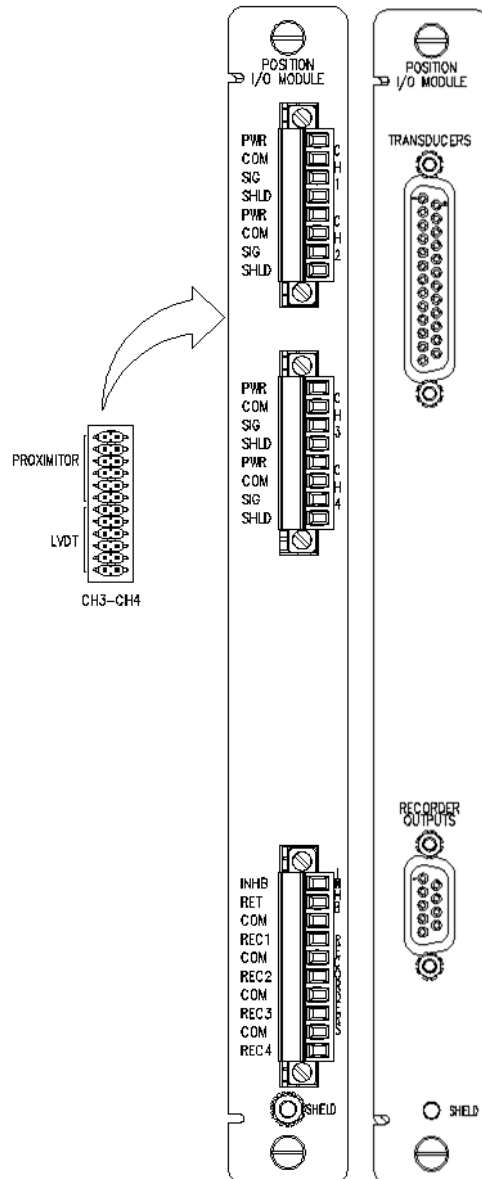
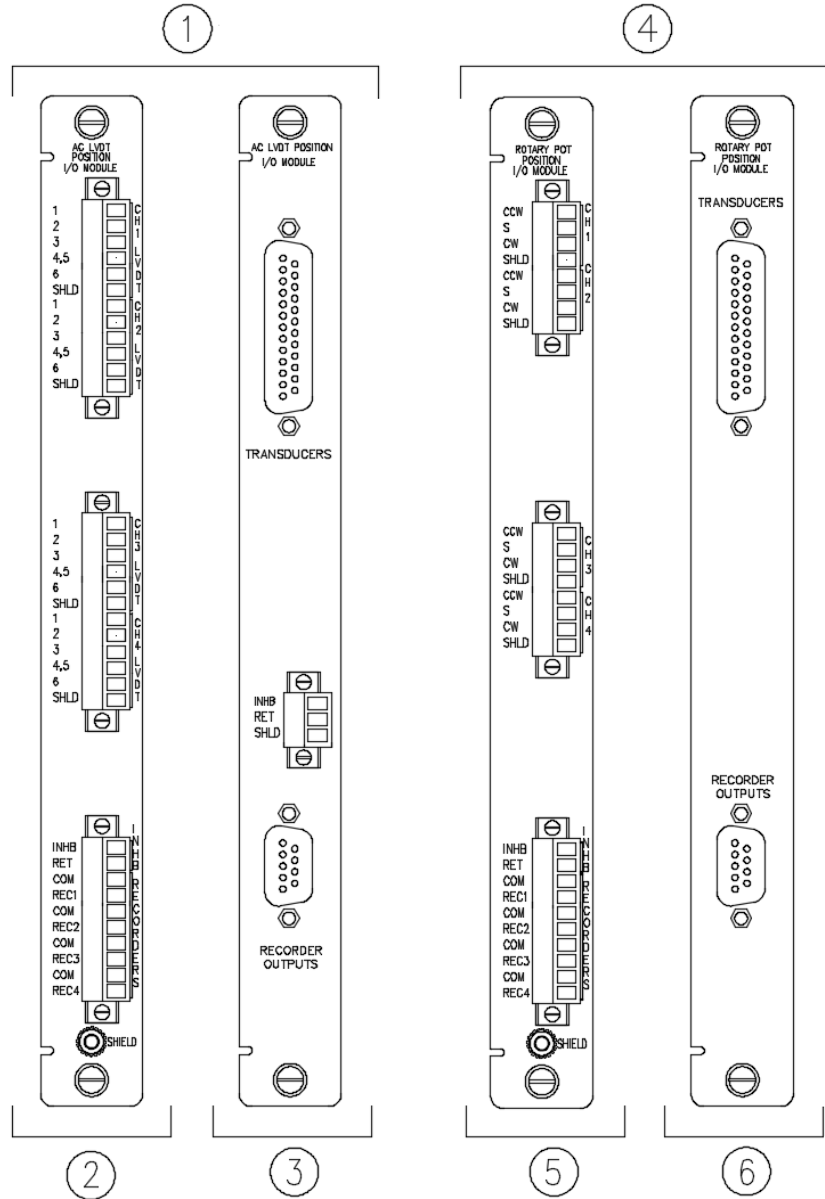

Figure 2: Side View of I/O Modules

The I/O modules with internal or external terminations have the same jumpers.



1. Rear Views of I/O Modules Used with AC LVDTs
2. Position I/O Module, Internal Termination, for Use with AC LVDTs
3. Position I/O Module, External Termination, for Use with AC LVDTs
4. Rear Views of I/O Modules Used with Rotary Potentiometers
5. Position I/O Module, Internal Termination, for Use with Rotary Potentiometers
6. Position I/O Module, External Termination, for Use with Rotary Potentiometers

Figure 3: I/O Modules for AC LVDTs and Rotary Potentiometers

Thrust and Valve Positions

Thrust Position

The following picture depicts the axial position of the rotor with respect to the thrust bearing or some fixed reference:

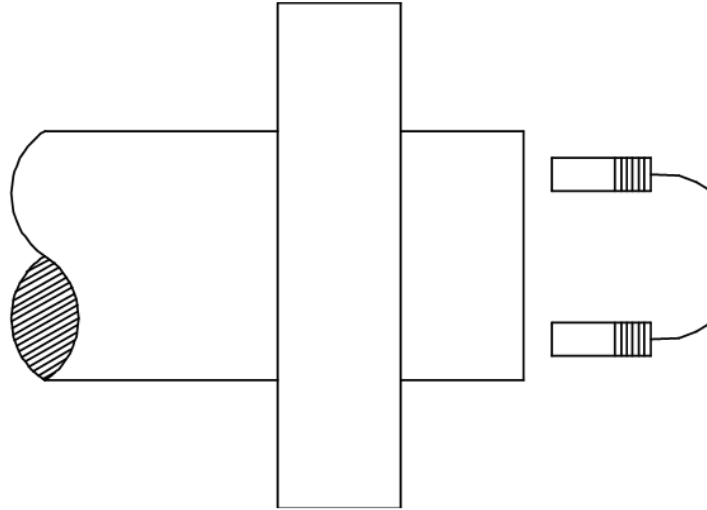

Valve Position

The following picture depicts the relative measurement of the position of a process inlet valve stem based on its full stroke, or the relative measurement of the rotational position of a cam shaft based on its full rotation:

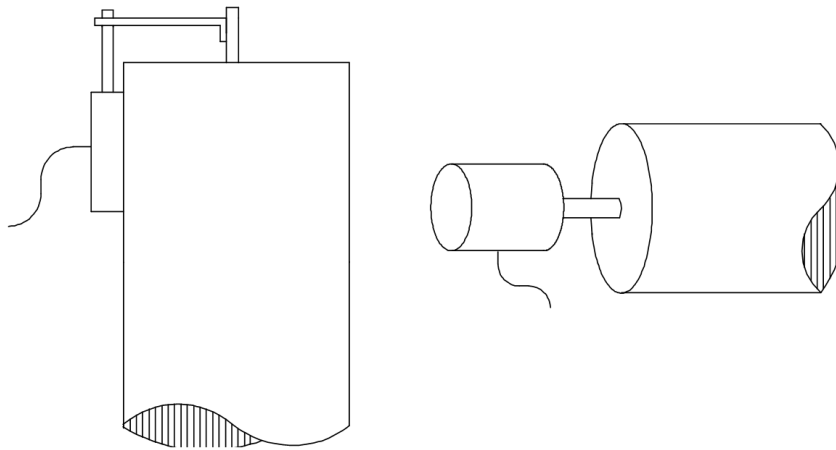

Differential Expansion

The following picture depicts shaft growth relative to the machine case:

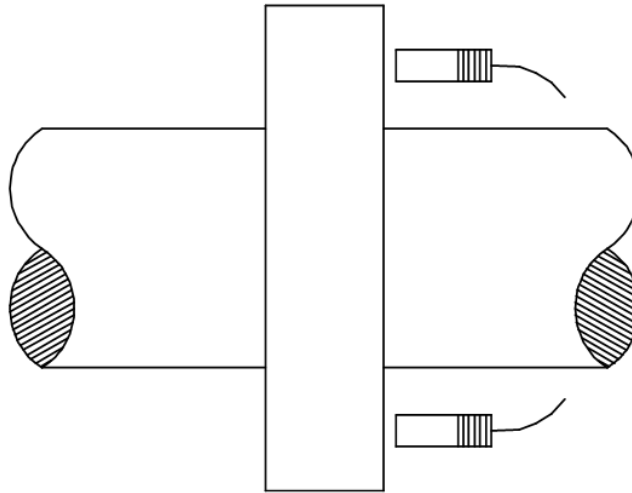

The following picture depicts standard single ramp differential expansion:

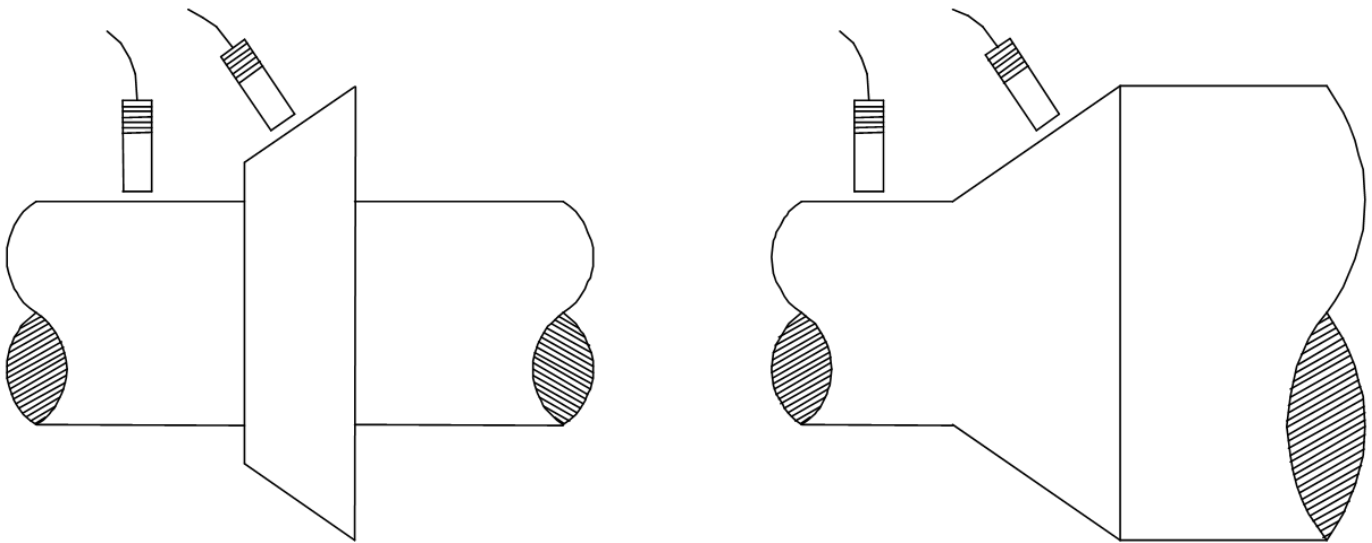

The following picture depicts non-standard single ramp differential expansion:

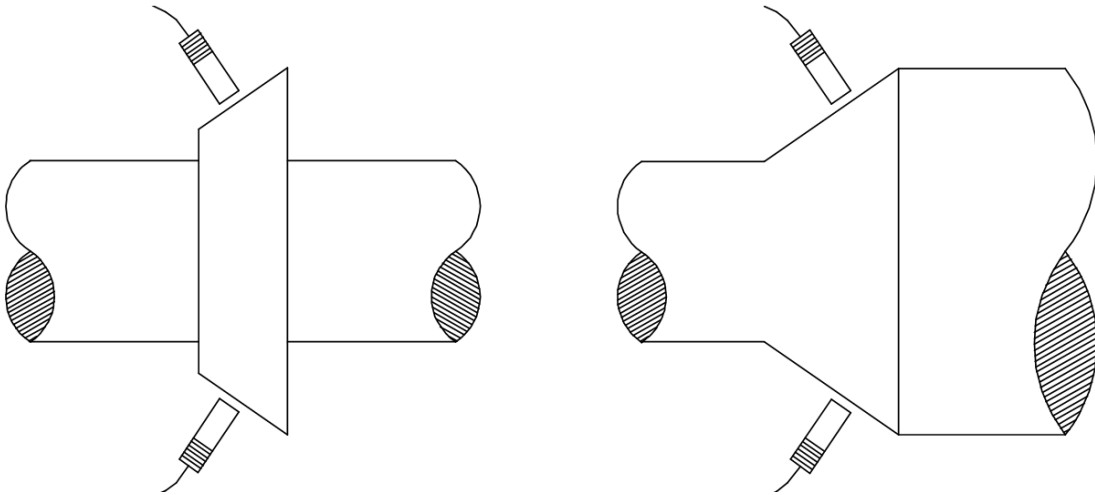

The following picture depicts a dual ramp differential expansion:

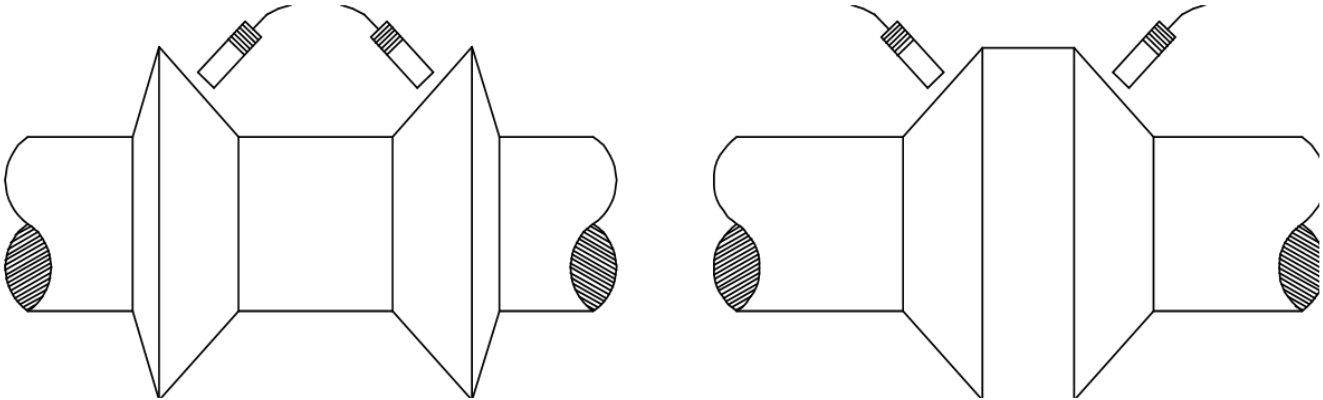

The following image depicts a complementary input differential expansion (CIDE) which uses a combination of two probes to increase the measurement range to twice the range of a single probe:

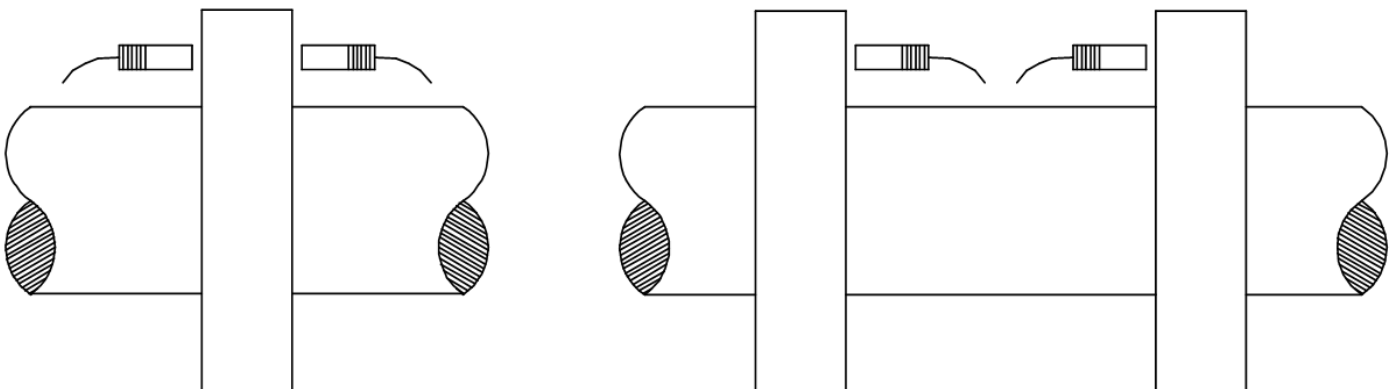

Case Expansion

The following picture depicts a single case expansion which is the measurement of the machine casing growth relative to its foundation:

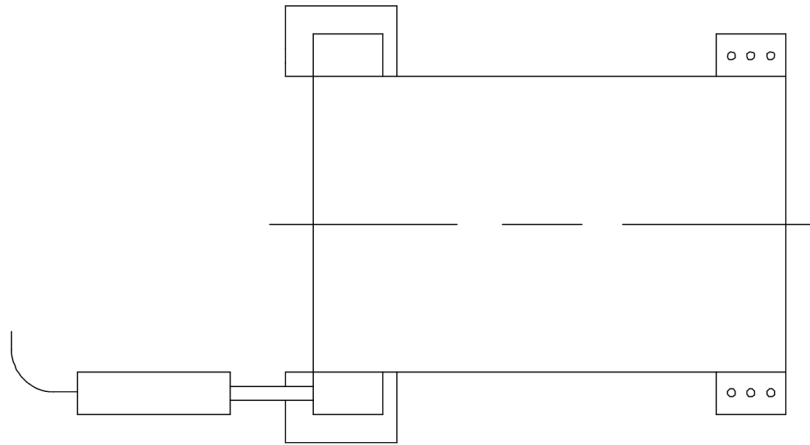

The following picture depicts a dual case expansion:

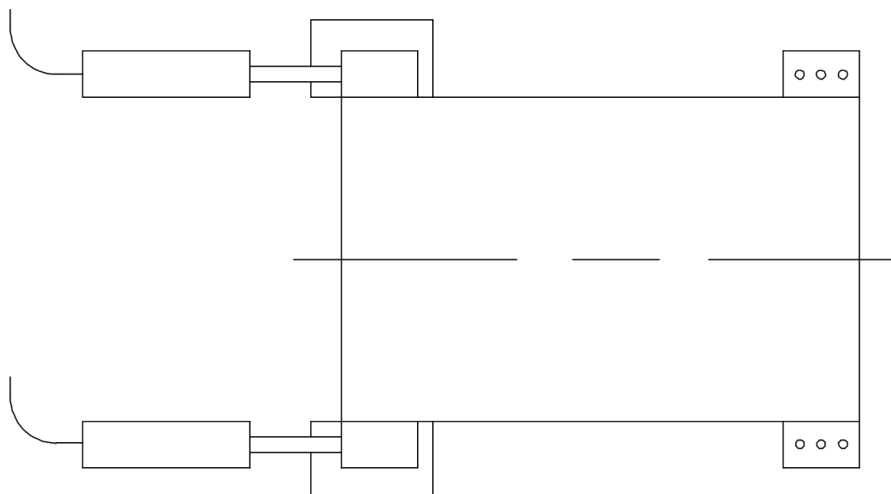

Copyright 2022 Baker Hughes Company. All rights reserved.



Bently Nevada, M2, Proximito and Orbit Logo are registered trademarks of Bently Nevada, a Baker Hughes business, in the United States and other countries. The Baker Hughes logo is a trademark of Baker Hughes Company. All other product and company names are trademarks of their respective holders. Use of the trademarks does not imply any affiliation with or endorsement by the respective holders.

Baker Hughes provides this information on an "as is" basis for general information purposes. Baker Hughes does not make any representation as to the accuracy or completeness of the information and makes no warranties of any kind, specific, implied or oral, to the fullest extent permissible by law, including those of merchantability and fitness for a particular purpose or use. Baker Hughes hereby disclaims any and all liability for any direct, indirect, consequential or special damages, claims for lost profits, or third party claims arising from the use of the information, whether a claim is asserted in contract, tort, or otherwise. Baker Hughes reserves the right to make changes in specifications and features shown herein, or discontinue the product described at any time without notice or obligation. Contact your Baker Hughes representative for the most current information.

The information contained in this document is the property of Baker Hughes and its affiliates; and is subject to change without prior notice. It is being supplied as a service to our customers and may not be altered or its content repackaged without the express written consent of Baker Hughes. This product or associated products may be covered by one or more patents. See [Bentley.com/legal](https://www.bentley.com/legal).

1631 Bently Parkway South, Minden, Nevada USA 89423
Phone: 1.775.782.3611 (US) or [Bentley.com/support](https://www.bentley.com/support)
[Bentley.com](https://www.bentley.com)