

Flowgrid™ Valve

250 Single Port

NPT, Flanged CL 150

The **Mooney™** 2" Single Port Flowgrid 250 Valve is a lower pressure and lower cost version of the 2" Large Single Port valve. It is a ductile iron and aluminum construction rated with a maximum inlet pressure of 250 psi. The Flowgrid 250 uses the same diaphragm and main spring that have proven reliability in the higher pressure valves.

Specifications

Size	2"
Body Style	Single Port (2")
End Connections	2" NPT, 2" CL 150 RF, 2" CL 150 FF
Temperature	Working -20°F to 150°F Emergency -40°F to 175°F
Max. Operating Differential	250 psi
Max. Emergency Differential	250 psi
Min. Differential	Refer to graph on page 2
Cracking Differential	Refer to graph on page 2
Max. Inlet Pressure	250 psig
Outlet Pressure Range	Limited by Pilot
Flow Direction	Bi-Directional ¹
Body Taps	Two 1/4" - 18NPT

1. Reverse flow by changing pilot connections and reversing spring case.

Materials of Construction

Body and Spring	Ductile Iron A395
Spring Case	A356-T6 Anodized Aluminum
Throttle Plate	Hard Anodized A356-T6 Aluminum
Diaphragm	Nitrile / Nylon ¹
Gasket	Nitrile Rubber
Bolting	ASTM A 193 GR 8
Spring	303 Stainless Steel
Restricting Plates	Zinc Plated Carbon Steel

1. Refer to diaphragm selection chart on page 2.

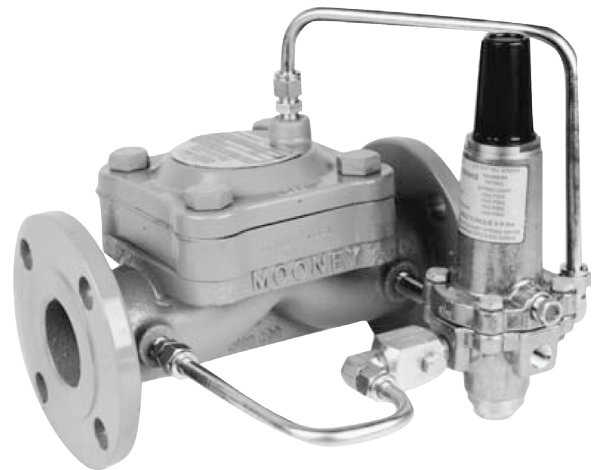

2" Flowgrid 250 with Series 20 Pilot

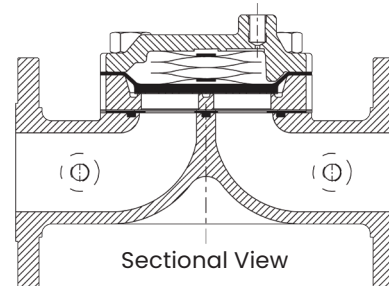

Overpressure Protection

The Flowgrid Valve is bi-directional and has a full ASME 250 psig rating on both the inlet and outlet. Overpressure protection is required only if the pressure can exceed the flange or body rating.

The pilots, like most regulators, may have an outlet pressure rating lower than the inlet pressure rating. If this is the case, then some external form of over-pressure protection must be provided for the pilot.

Anytime the Flowgrid valve or pilot system is exposed to pressure in excess of its rating, it should be inspected for damage.

Stock Numbers

2" Flowgrid 250	Stock Number	Weight
2" NPT	FG-82	20 lbs.
2" CL 150 RF	FG-83	30 lbs.
2" CL 150 FF	FG-84	30 lbs.

Dimensions

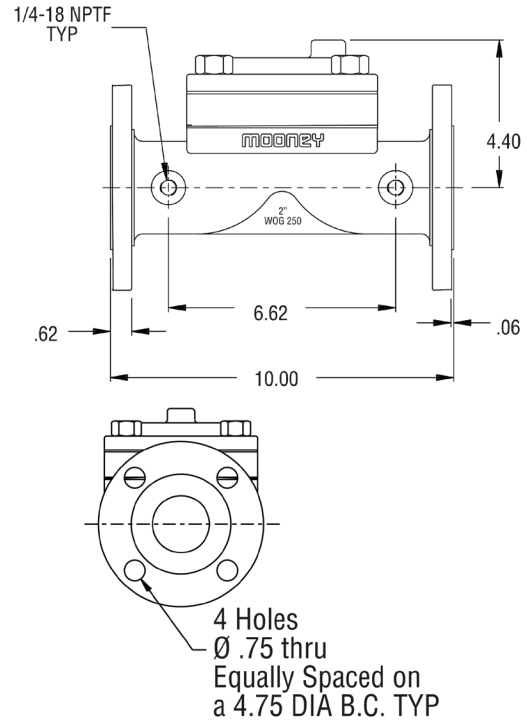
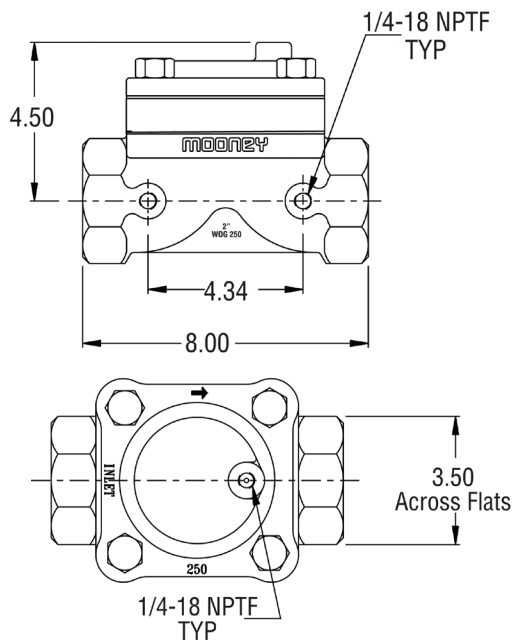

Minimum Pressure Differential vs. Capacity

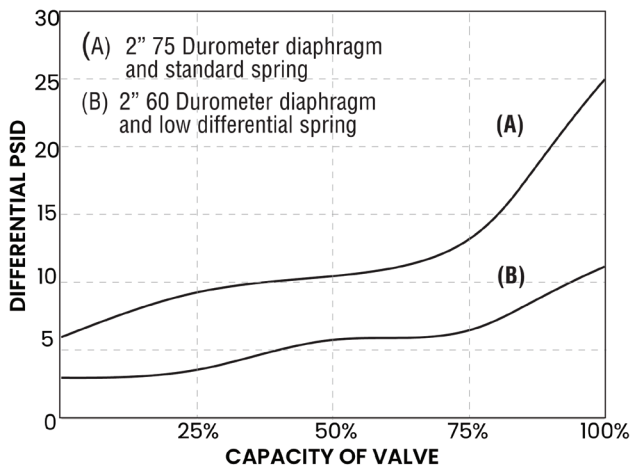

Flow Coefficients and Constants

2" Flowgrid 250 Valve				Swage Factor	
% Capacity	C _v	C _i	C _g	1.5:1	2:1
100%	46	35	1600	0.97	0.96
75%	37	33	1230	0.98	0.97
50%	27	30	820	0.99	0.98
25%	19	30	560	1.00	1.00

Note: Allow a 5% factor of safety when calculating relief capacity.

Diaphragm Selection

Compound	Temp. Range (°F)	Maximum Differential	Characteristics	Recommended Applications
75 Duro	-20 to 150	250 psid ¹	Best All Around Material	60 psid to Max. Differential
60 Duro	-25 to 150	250 psid ¹	Best Shutoff at Low Differential Pressure	Low Differential (100 psid or less) or Low Temperature

1. Limited by body rating.

Baker Hughes 