

# 1900/65A General Purpose Equipment Monitor

## Datasheet

Bently Nevada Machinery Condition Monitoring

173401 Rev. Y



### Description

The 1900/65A General Purpose Equipment Monitor is designed to continuously monitor and protect equipment that is used in a variety of applications and industries. The monitor's low cost makes it an ideal solution for general-purpose machines and processes that can benefit from continuous monitoring and protection.

### Inputs

The 1900/65A provides four transducer inputs and four temperature inputs. Software can configure each transducer input to support 2- and 3-wire accelerometers, velocity sensors, or proximity sensors. Each temperature input supports Type E, J, K, and T thermocouples, and 2- or 3-wire RTDs.

### Outputs

The 1900/65A provides six relay outputs, four 4-20 mA recorder outputs, and a dedicated buffered output. The user can use the 1900 Configuration software to configure the relay contacts to open or close according to the OK, Alert, and Danger statuses of any channel or combination of channels, and to provide data from any variable from any channel on any recorder output. The dedicated buffer output can provide the signal for each transducer input.



A Modbus Gateway option allows the monitor to provide static variables, statuses, event list, time, and date information directly to any Modbus client, including Distributed Control Systems (DCSs), Supervisory Control and Data Acquisition (SCADA) systems, Programmable Logic Controllers (PLCs), or System 1 software. The monitor uses an internal counter and a Modbus client/master time reference to generate time and date information. Users can upgrade monitors without the Modbus Gateway by ordering the 1900/01 Communications Upgrade ([see Ordering Information on page 16](#)). The 1900/65A supports Modbus communications via Ethernet and a software-configurable RS232/485 serial port.

## Configuration

The user defines monitor operation and the Modbus Gateway register map by using software running on a laptop or PC to create a configuration file and download the file to the monitor through the built-in Ethernet connection. The 1900/65A permanently stores configuration information in non-volatile memory, and can upload this information to the PC for changes.

## Display Module

The 1900/65A supports an optional display/keypad to view channel information or make minor configuration changes. This allows the 1900/65A to operate as a stand-alone package. If desired, the user can mount the display up to 75 metres (250 feet) from the Monitor Module.

## Specifications

### Inputs

#### Transducer Inputs

Users can configure Channels 1 through 4 to accept input from acceleration, velocity, or displacement transducers.

#### Transducer Channel Types

**Channel Types** define the functionality for processing that will be applied to an input signal and the kind of variables or measurement values that will be derived from this input. Channel Types also define the kind of sensor that must be used. Transducer Channel Types include:

- Acceleration or Reciprocating Acceleration
- Velocity or Reciprocating Velocity
- Radial Vibration (shaft vibration)
- Thrust (shaft axial displacement)
- Position
- Speed

#### Acceleration and Reciprocating Acceleration Channel Types

The Acceleration Channel Type and Reciprocating Acceleration Channel Type support two- and three-wire acceleration sensors. The Reciprocating Acceleration channel type has timed OK channel defeat disabled.

## Acceleration Variables and Reciprocating Acceleration Variables

Acceleration Variables and Reciprocating Acceleration Variables are filtered and processed measurements from raw transducer signals. The Acceleration Channel Type and Reciprocating Acceleration Channel Type continuously processes up to four variables per channel.

Vibration	Up to three bandpass filtered amplitude measurements.
Acceleration Enveloping	Users can apply the acceleration enveloping algorithm to one Acceleration or Reciprocating Acceleration Variable.
Bias Voltage	Users may assign the value of the transducer bias voltage to any of the variables.

### Configuration Options

Each variable is independently configured with the following options.

Vibration Variables	<ul style="list-style-type: none"> <li>• Peak or RMS</li> <li>• Metric or English units</li> <li>• Filter corner frequencies</li> <li>• Full scale range</li> <li>• Acceleration integrated to velocity</li> </ul>
Enveloped Variable	<ul style="list-style-type: none"> <li>• Filter corner frequencies</li> <li>• Standard or Enhanced demodulation</li> </ul>

## Filters

Vibration Variable	0.5 Hz to 25 kHz configurable 4-pole high-pass, 4-pole low-pass
Enveloping High-Pass	25 Hz to 5 kHz, configurable 4-pole
Enveloping Low-Pass	125 Hz to 25 kHz, configurable 2-pole
Enveloped Variable High-Pass	0.1 Hz min., but greater than Enveloped Variable low-pass 2-pole
Enveloped Variable Low-Pass	Greater than Enveloped Variable high-pass and less than Enveloping high-pass 4-pole
Bias Filter	0.01 Hz 1-pole low-pass
OK Filter	2.4 kHz 1-pole low-pass

## Full Scale Range

Vibration	20 m/s <sup>2</sup> to 500 m/s <sup>2</sup> (2 g to 50 g) peak and RMS
Enveloped	20 m/s <sup>2</sup> to 500 m/s <sup>2</sup> (2 g to 50 g) peak and RMS
Integrated	10 mm/s to 100 mm/s (0.4 in/s to 4 in/s) peak and RMS
Bias Voltage	-24 V

## Accuracy

Vibration Variables	±1% of full scale range
---------------------	-------------------------

## Input Impedance

3-wire Voltage Mode	10 kΩ
---------------------	-------

## Velocity and Reciprocating Velocity Channel Type

The Velocity Channel Type and Reciprocating Velocity Channel Type support two-wire and three-wire piezo-velocity sensors.

## Velocity Variables and Reciprocating Velocity Variables

Velocity Variables and Reciprocating Velocity Variables are filtered and processed measurements from raw transducer signals. The Velocity Channel Type and Reciprocating Velocity Channel Type support up to four continuously calculated variables per channel.

Vibration	Up to three bandpass filtered amplitude measurements.
Bias Voltage	Users may assign the value of the transducer bias voltage to any of the variables.

## Configurable Options

Each variable is independently configured with the following options.

Vibration Variables	<ul style="list-style-type: none"> <li>• Peak or RMS</li> <li>• Metric or English units</li> <li>• Filter corner frequencies</li> <li>• Full-scale range</li> <li>• Velocity integrated to displacement</li> </ul>
---------------------	--

## Filters

Vibration Variables	0.5 Hz to 5.5 kHz, configurable 8-pole high-pass, 4-pole low-pass
Bias Filter	0.09 Hz 1-pole low-pass
OK Filter:	2.4 kHz 1-pole low-pass

## Full Scale Range

Vibration	10 mm/s to 50 mm/s (0.5 in/s to 2 in/s) peak and RMS
Integrated	100 $\mu$ m to 500 $\mu$ m (5 mils to 20 mils) peak to peak
Bias Voltage	-24 V

## Accuracy

Vibration Variables	$\pm$ 1% of full scale range
---------------------	------------------------------

## Input Impedance

3-Wire Voltage Mode	10 k $\Omega$
---------------------	---------------

## Radial Vibration Channel Type

The Radial Vibration Channel Type measures radial shaft motion using proximity sensors.

## Radial Vibration Variables

*Radial Vibration Variables are filtered and processed measurements from raw transducer sensors. The Radial Vibration Channel Type supports up to four continuously calculated variables per channel.*

Direct	Up to three bandpass filtered amplitude measurements
Gap	Gap voltage
Vibration	Up to three bandpass filtered amplitude measurements

## Configurable Options

Each variable is independently configured with the following options.

Vibration Variables	<ul style="list-style-type: none"> <li>• Metric or English units</li> <li>• Filter corner frequencies</li> <li>• Number of filter poles</li> <li>• Full-scale range</li> </ul>
---------------------	--

## Filters

Direct Filter 1	4 Hz to 4000 Hz (240 RPM to 240,000 RPM)
Direct Filter 2	1 Hz to 600 Hz (60 RPM to 36,000 RPM)
Direct Filter Characteristics	High-pass set by attack and decay, 1-pole low-pass
Gap Filter	0.09 Hz 1-pole low-pass
Vibration Variables	0.5 Hz to 4 kHz, configurable 1-, 2-, or 4-pole high-pass and low-pass, configurable
OK Filter	2.4 kHz 1-pole low-pass

## Full Scale Range

Direct	100 $\mu$ m to 500 $\mu$ m (3 mils to 20 mils) peak-to-peak
Gap	-24 V

### Accuracy

Vibration Variables	±1% of full-scale range
---------------------	-------------------------

### Input Impedance

Non-configurable	10 kΩ
------------------	-------

### Thrust Channel Type

The Thrust Channel Type measures axial shaft motion using proximity sensors.

### Thrust Variables

Thrust Variables are filtered and processed measurements from raw transducer signals.

Position	Axial position of shaft
Gap	Gap, voltage or position

### Configurable Options

Each variable is independently configured with the following options.

Position Variables	Metric or English units
	Full-scale range

### Filters

Direct Filter:	1.2 Hz 1-pole low-pass
Gap Filter	0.41 Hz 1-pole low-pass
OK Filter:	2.4 kHz 1-pole low-pass

### Full Scale Range

Position	1 mm to 4 mm (50 mils to 150 mils) span with adjustable zero position
Gap	-24 V

### Accuracy

Position Variables	±1% of full-scale range
--------------------	-------------------------

### Input Impedance

Non-configurable	10 kΩ
------------------	-------

### Position Channel Type

The Position Channel Type measures mechanical motion using proximity sensors.

### Position Variables

Position Variables are filtered and processed measurements from raw transducer signals.

Position	Mechanical position
Gap	Gap, voltage or position

### Configurable Options

Each variable is independently configured with the following options.

Position Variables	Metric or English units
	Full- scale range

### Filters

Direct Filter	1.2 Hz 1-pole low-pass
Gap Filter	0.41 Hz 1-pole low-pass
OK Filter	2.4 kHz 1-pole low-pass

### Full Scale Range

Position	1 mm to 28 mm (50 mils to 1100 mils) span with adjustable zero position.
Gap	-24 V

## Accuracy

Position Variables	±1% of full scale range
--------------------	-------------------------

## Input Impedance

Non-configurable	10 kΩ
------------------	-------

## Speed Channel Type

The Speed Channel Type measures speed using proximity sensors.

## Speed Variables

Speed Variables are filtered and processed measurements from raw transducer signals.

Speed	Up to 4 speed measurements
Gap	Gap, voltage

## Configurable Options

Each variable is independently configured with the following options:

Gap Filter	0.09 Hz 1-pole low-pass
OK Filter	2.4 kHz 1-pole low-pass

## Full Scale Range

Speed	100 RPM to 100,000 RPM
-------	------------------------

## Events Per Revolution

EPR	0.001 to 1000
-----	---------------

## Accuracy

Speed Variables:	± 0.5 RPM + 0.015% of reading
------------------	-------------------------------

## Input Impedance

Non-configurable	10 kΩ
------------------	-------

## Temperature Inputs (Ch. 5 – 8)

Channels 5 through 8 support Type E, J, K, and T thermocouples, and 2- and 3-wire RTDs.

## Temperature Variable

Temperature variables are processed measurements from raw transducer signals. The temperature channel type processes one temperature variable per channel.

## Configurable Options

Each Variable is independently configured with the following options.

Units	°C or °F
-------	----------

## Filters

Analog Filter	50 Hz 1-pole, low-pass
Digital Filter	Notch filter will attenuate the first 5 orders of 50 Hz and 60 Hz (49 Hz to 61 Hz) by a minimum of 100 dB.

## Full Scale Range

Type E	-200°C to 1000°C (-328°F to 1832°F)
Type J	-210°C to 1200°C (-346°F to 2192°F)
Type K	-200°C to 1370°C (-328°F to 2498°F)
Type T	-200°C to 400°C (-328°F to 752°F)
10 Ω Cu α=0.00427	-200°C to 260°C (-328°F to 500°F)

120 Ω Ni α=0.00672	-80°C to 260°C (-112°F to 500°F)
100 Ω Pt α=0.00385:	-200°C to 850°C (-328°F to 1562°F)
100 Ω Pt α=0.00392:	-200°C to 700°C (-328°F to 1292°F)

### Accuracy

All Thermocouple Types	±1°C (±1.8°F) typical @ 25°C (77°F) ±2.5°C (±4.5°F) maximum for thermocouple measurements over -100°C (148°F) ±5°C (±9°F) maximum for thermocouple measurements below -100°C (-148°F)
3-Wire RTD (except 10 Ω Cu)	±1.5°C (±2.7°F) + 0.5 % full scale
3-Wire RTD 10 Ω Cu	±3°C (±5.4°F) + 0.5 % full scale
2-wire RTD Types	2-wire RTDs have additional errors due to field wire resistance and variations in the field wire resistance due to changes in ambient temperature.

### Input Impedance

Thermocouple Inputs	>1 MΩ
---------------------	-------

### Alarm Status Time Delays

#### Position/ Vibration Inputs

Minimum	0.1 second
Maximum	60 seconds

Adjustment Resolution	0.1 second
-----------------------	------------

### Temperature / Speed Inputs

Minimum	1 second
Maximum	60 seconds
Adjustment Resolution	0.1 second

### Relays

#### Relay Logic

The 1900/65A monitor has six relay outputs that users can program to open or close contacts according to user-defined logic statements. Logic statements use the OK, Alert and Danger statuses of any channel, or combination of channels as inputs.

#### Logical Operators

AND	bypassed channels ignored
True AND	bypassed channels included
OR	

#### Logical Operands

- Monitor Inhibit
- Monitor Not OK
- Monitor Danger
- Monitor Alert
- Channel Not OK
- Channel Danger
- Channel Alert
- Variable Danger
- Variable Alert



## Maximum Operands

50 per relay

## Relay Configuration

The following configuration options are independent of the relay logic and can be configured for each relay:

- Latching or non-latching independent of alarm status
- Normally energized or normally de-energized
- Normally open and normally closed via contacts

## Relay Specifications

### Type

Single pole, double throw (SPDT)

### Contact Ratings

Minimum Switched Current	12 Vdc / 100 mA
--------------------------	-----------------

### DC specifications (resistive load)

Maximum Switched Current	5 A
Maximum Switched Power	70W @ 24 Vdc 10W @ 48 Vdc 9W @ 60 Vdc
Maximum Switched Voltage	60 Vdc

### AC specifications (resistive load)

Maximum Switched Current	5 A
Maximum Switched Power	150 VA
Maximum Switched Voltage	30 Vac



Refer to [Hazardous Area Special Considerations](#) for Relay specifications when used in hazardous area applications.

## Contact Life

100,000 cycles @ 5 A, 250 Vac

200,000 cycles @ 1 A, 24 Vdc

## Sealing

Epoxy

## Insulation Resistance

1000 MΩ minimum @ 500 Vdc

## Inhibit, Reset, and Trip Multiply Inputs

### Inhibit/Trip Multiply

Users can use software to configure the Inhibit/Trip Multiply input as either Inhibit or Trip Multiply.

When configured for Trip Multiply short-circuiting the Inhibit/Trip Multiply contact to RTN will increase Alert and Danger set points.

When configured for Inhibit the Inhibit input will inhibit (bypass or inactivate) Alert and Danger statuses. Short circuiting the INHIBIT contact to INHIBIT RTN will:

- Set all Variable Danger Statuses to logic 0
- Set all Variable Alert Statuses to logic 0
- Set Bypass and Inhibit Statuses to logic 1



**Monitor Alarm Inhibit switch, and Monitor Trip Multiply switch** mapped in the Modbus Gateway will remotely inhibit **Alert** and **Danger** statuses or activate **Trip Multiply** respectively.

### Electrical

Activate Inhibit	50 kΩ or less (shorted)
De-activate Inhibit	500 kΩ or greater (open)

### Reset

Use the Reset input to reset all latched alarms and latched relays. If the condition driving the status no longer exists, short-circuiting the RESET contact to RESET RTN will:

- Reset all latched Alert statuses
- Reset all latched Danger statuses
- Reset all latched Not OK statuses
- Reset all latched relays



Writing a non-zero value to the Modbus register **Reset Latched Statuses** mapped in the Modbus Gateway will reset the monitor remotely.

### Electrical

Activate Reset	50 kΩ or less (shortened)
De-activate Reset	500 kΩ or greater (open)

### Transducer Supplies

All outputs are short-circuit protected.

### Two-Wire Current Mode

Current Source	3.3 mA ± 5%
----------------	-------------

Open Circuit Voltage	21 Vdc to 24 Vdc
----------------------	------------------

### Three-Wire Voltage Mode

Supply Voltage	-24.02 Vdc to -23.47 Vdc
Maximum Rated Current	15 mA
Short Circuit Current	15.1 mA to 23.6 mA

### 4-20 mA Interface

Number of Outputs	Four outputs, any of which may be configured to provide data from any channel and any variable.
Proportional Value	4 to 20 mA values are proportional to the channel full-scale.
Loop Supply Voltage	18 to 36 Vdc
Loop Resistance	600 Ω maximum
Accuracy	2% over operating temperature range
Update Rate	100 mS
Resolution	10 mA
Clamp Current	2 mA ± 10% (configurable for Not OK and Bypass)

### Buffered Outputs

### Display Module

A single buffered output on the Display Module provides access to input Channels 1 through 4. The signal does not have gain, and is not scaled. This output is buffered to provide short circuit and EMI protection.

Output Impedance	550 $\Omega$
Bandwidth	40 kHz minimum (Display Module attached directly to Monitor)  8 kHz minimum (75 m [250 ft] of cable)

### Monitor Module

Each input for channels 1 through 4 has a dedicated buffered output. The signal does not have gain, and is not scaled. Each output is buffered to provided short circuit and EMI protection.

Output Impedance	550 $\Omega$
Bandwidth	40 kHz minimum

### Indicators

#### Monitor Module

<b>Status LED</b>	Indicates when the monitor is functioning properly.
-------------------	---

#### Display Module

OK LED	Indicates when the monitor is functioning properly.
Alert LED	Indicates an Alert condition.
Danger LED	Indicates a Danger condition.
Bypass LED	Indicates that the monitor is in Bypass mode.
Trip Multiply LED	Indicates that the monitor is in Trip Multiply mode.
Channel LED	Indicates channel is active.
Display	Liquid Crystal Display (LCD) with backlight

Dimensions	68.6 mm (2.7 in) wide x 35.6 mm (1.4 in) high
------------	---

### Power Requirements

Input Voltage Range	18 to 36 Vdc
Operating Current	0.35 A typical, 1.0 A maximum
Operating Power	8.5 W typical, 14 W maximum

### Physical

#### Monitor Module

Dimensions (L x W x H)	196.9 mm x 149.4 mm x 74.4 mm (7.75 in x 5.88 in x 2.93 in)
Weight	0.77 kg (1.70 lb)

#### Display Module

Dimensions (L x W x H)	196.9 mm x 149.4 mm x 32.8 mm (7.75 in x 5.88 in x 1.29 in)
Weight	0.40 kg (0.89 lb)

### Mounting

DIN Rail Option	35 mm DIN rail
Bulkhead Option	Bulkhead mounting plate
Weatherproof Enclosure Option	NEMA 4X/IP66 Fiberglass Housing with window, 300.2 mm x 249.4 mm x 209.8 mm (11.82 in x 9.82 in x 8.26 in)

## Configuration Software

The 1900 Configuration Software package contains everything necessary to install, configure, and maintain the 1900/65A monitor.

- Configuration Software
- Feature tools for installing and troubleshooting
- Simple display to help with configuration
- Ability to browse network for 1900 monitors
- Network configuration
- Configuration for channels, variables, setpoints, tag names, recorders, and filters
- Configuration for the optional Modbus Gateway
- Configuration for relays and relay voting logic
- Off-line configuration allowing use of software when hardware is not available
- Firmware upgrade function and diagnostics
- Change bypass modes and setpoints on the fly
- Display component for statuses and variables
- Display Hardware Identification and manufacturing information
- Context-specific help

## Environmental

### Temperature

Operating	-20°C to +70°C (-4°F to +158°F)
Storage	-30°C to +90°C (-22°F to +194°F)

### Humidity

Operating	95% non-condensing, maximum
Storage	95% non-condensing, maximum

## Supported Transducers

Channel Type	Bently Nevada Transducer
Acceleration and Reciprocating Acceleration	330400 Accelerometer
	330425 Accelerometer
Velocity and Reciprocating Velocity	190501 Velomitor
	330500 Velomitor
	330525 Velomitor
	330750 Velomitor
Radial Vibration, Thrust, and Speed	3300 5 & 8 mm Proximitor System
	3300 XL 8 mm Proximitor System
	3300 XL 11 mm Proximitor System
	3300 XL NSv Proximitor System
	7200 5 & 8 mm Proximitor System
	7200 11 mm Proximitor System
	7200 14 mm Proximitor System

Position	3300 5 & 8 mm Proximator System
	3300 XL 8 mm Proximator System
	3300 XL 11 mm Proximator System
	3300 XL 25 mm Proximator System
	3300 XL 50 mm Proximator System
	3300 XL NSv Proximator System
	7200 5 & 8 mm Proximator System
	7200 11 mm Proximator System
	7200 14 mm Proximator System



The 1900/65A provides default configuration settings for Bently Nevada transducers. The user can configure the 1900/65A to accept other transducers.

## Compliance and Certifications

### FCC

This device complies with part 15 of the FCC Rules. Operation is subject to the following two conditions:

- This device may not cause harmful interference.
- This device must accept any interference received, including interference that may cause undesired operation.

### EMC

EN 61000-6-2: 2005

EN 61000-6-4: 2007 +A1:2001

EMC Directive 2014/30/EU

### Electrical Safety

EN 61010-1: 2010

LV Directive 2014/35/EU

### ATEX

EN 60079-0: 2012

EN 60079-15: 2010

ATEX Directive 2014/34/EU

### RoHS

RoHS Directive 2011/65/EU

### Maritime

ABS 2009 Steel Vessels Rules

1-1-4/7.7,4-8-3/1.11.1,4-9-7/13

## Hazardous Area Approvals



For the detailed listing of country and product-specific approvals, refer to the [Approvals Quick Reference Guide \(108M1756\)](#).

For additional technical documentation, please log in to [bntechsupport.com](http://bntechsupport.com) and access the Bently Nevada Media Library.



This monitor is not certified for installation in Class 1 Div 1 locations, but it will support transducers installed in Div 1 locations via the use of galvanic isolators and barriers. If galvanic isolators are used, no change is necessary to the installation. A removable ground jumper allows the monitor to support zener barrier installations. Removing the jumper will disconnect circuit common from chassis at the monitor so that chassis can be connected at the barrier.

### cNRTLus

Ex/ AEx nA nC IIC Gc:  
Class I, Zone 2:  
Class I, Division 2, Groups A, B, C,  
and D  
T4 @ -20°C [Ta [+70°C  
Vn = 18 to 36 Vdc @ Imax = 1A  
per drawing 173089

### ATEX/IECEx



II 3 G  
Ex nAC IIC T4 Gc

T4 @ Ta = -20°C [Ta [+70°C

## Special Considerations

- Hazardous area installations require relay contact voltages below 30 Vac rms, or 30 Vdc to minimize hazard.
- Hazardous area installations require relay contact amperages below 5 Amps DC, or AC to minimize hazard.

## Ordering Information



For the detailed listing of country and product-specific approvals, refer to the [Approvals Quick Reference Guide \(108MI756\)](#).

For additional technical documentation, please log in to [bntechsupport.com](http://bntechsupport.com) and access the Bently Nevada Media Library.

## 1900/65A General Purpose Equipment Monitor



The Configuration Software is included with the monitor.

1900/65A-AA-BB-CC-DD-EE

### A: Power Option

00	18 Vdc to 36 Vdc
01	110 Vac to 220 Vac @ 50 to 60 Hz (external supply)

### B: Display Option

00	No display
01	Attached display (no cable)
02	Display with 10' PVC cable
03	Display with 10' unassembled PVC cable
04	Display with 10' TEF cable
05	Display with 10' unassembled TEF cable

### C: Mounting Option

00	None
01	DIN rail mount
02	Bulkhead Mount
03	Fiberglass NEMA 4X/IP66 WP housing with window in door

04	1900/55 replacement kit ( <a href="#">see Weatherproof Housing Dimensions on page 22</a> )*
07	ProTIM Housing, Wiring and Mounting Hardware ( <a href="#">see ProTIM Housing Dimensions on page 25</a> )



\* Uses existing 1900/55 weatherproof housing and requires power option A01 (110/220 Vac to 24 Vdc external power supply)

### D: Approvals Options

00	None
01	Multiple approvals

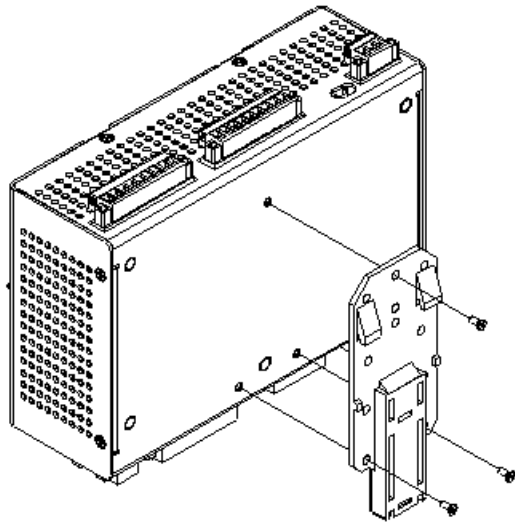


See [Hazardous Areas Approvals](#) section for specific certifications. Maritime approvals included with all approval options.

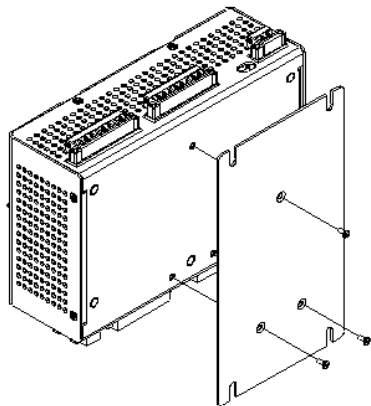
### E: Communications Option

00	None
01	Modbus communications

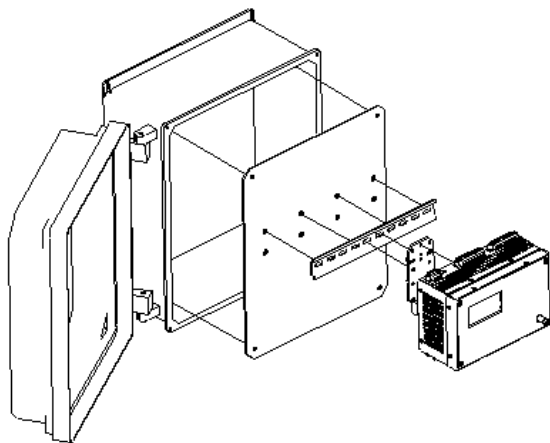




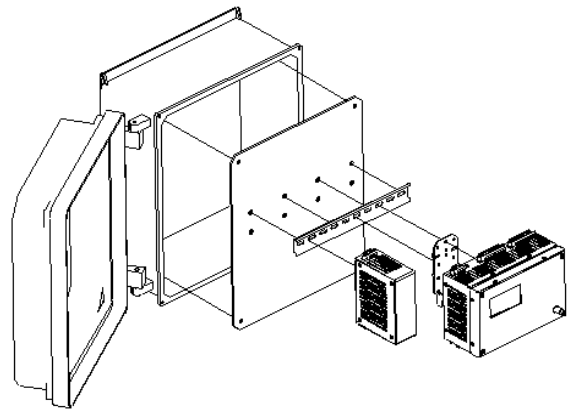
**Figure 1: DIN Rail Mount**



**Figure 2: Bulkhead Mount**



**Figure 3: NEMA 4X/IP66\_WP\_Housing**



**Figure 4: 1900/55 Replacement Kit**

**1900/01 – 1900/65A General  
 Communications Monitor,  
 Communications Upgrade**

1900/01-AA-BB

**A: Order Type Option**

<b>01</b>	New order (CD, key, and binder)
<b>98</b>	Replacement licenses (key)
<b>99</b>	Configuration Software only (CD)

**B: Communications Option**

<b>01</b>	Modbus comm.
-----------	--------------

## Accessories

Part Number	Description
167699-02	1900/65A Display Module
173400	<i>1900/65A User Guide</i>
172250	<i>1900/65 Modbus Gateway Users Guide</i>
173089	<i>1900/65A Field Wiring Diagrams</i>
02200794	Power supply, 110/220 Vac to 24 Vdc 2.5 A DIN rail mount
02200121	DIN rail end bracket
168374	35mm DIN rail mounting clip for 1900/65A Monitor Module
168495	Bulkhead mounting plate
168547-0010-01-01	3 m (10 ft) PVC cable, assembled
168547-0010-01-02	3 m (10 ft) PVC cable, unassembled
168547-0010-02-01	3 m (10 ft) TEF cable, assembled
168547-0010-02-02	3 m (10 ft) TEF cable, unassembled
168628	Stainless steel NEMA 4X weatherproof door for panel-mount display assembly
168629	Painted steel NEMA 4 weatherproof door for panel-mount display assembly
168944	Fiberglass NEMA 4X/IP66 weatherproof housing with window in door
284785	MTL 7728(-) barrier
175502	MTL 7796(-) barrier

Part Number	Description
172555	Modbus/TCP (Ethernet) to Modbus/RTU (Serial) Converter
169825-01	Training CD

## Graphs and Figures



All dimensions shown in millimeters (inches) except as noted.

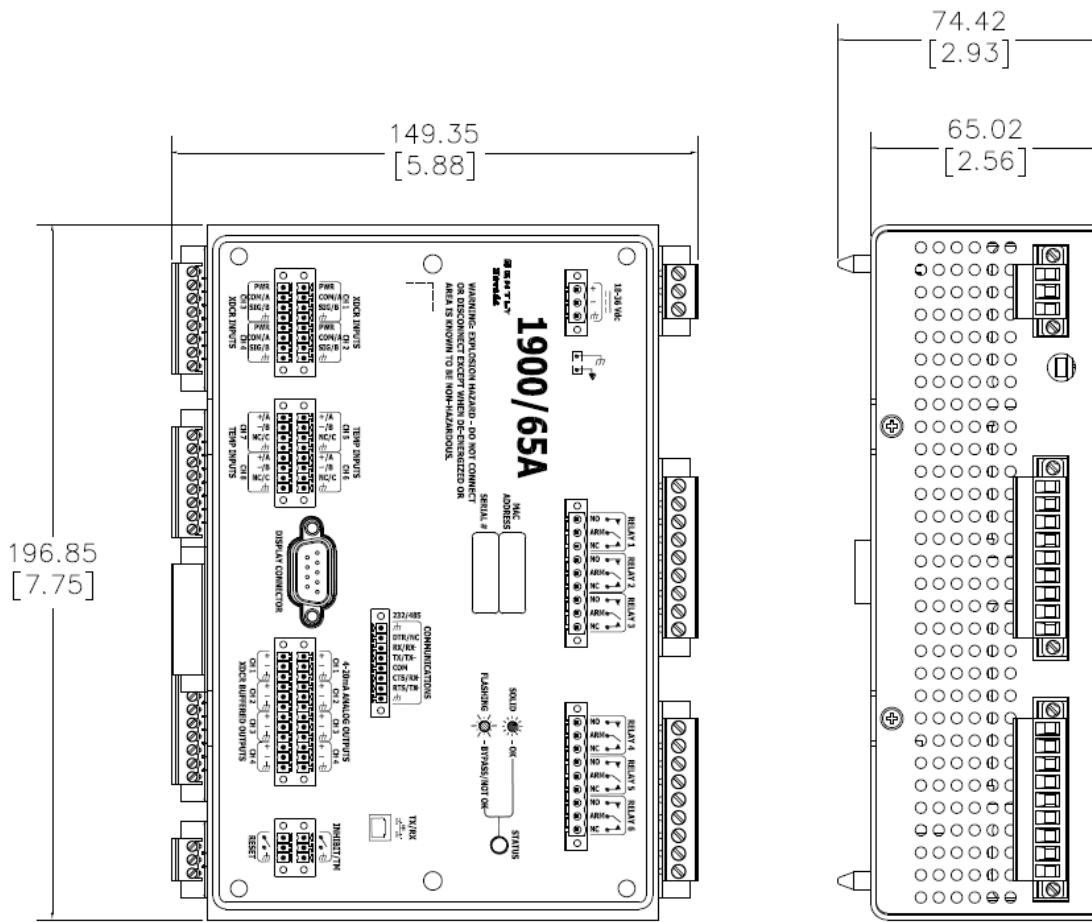
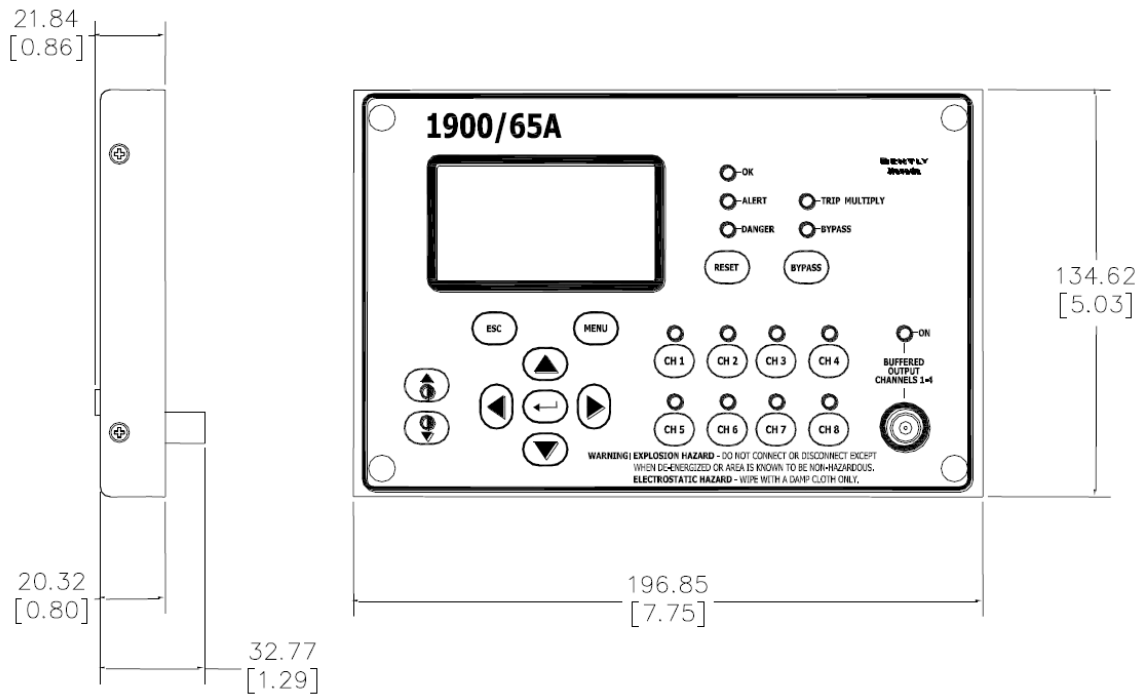
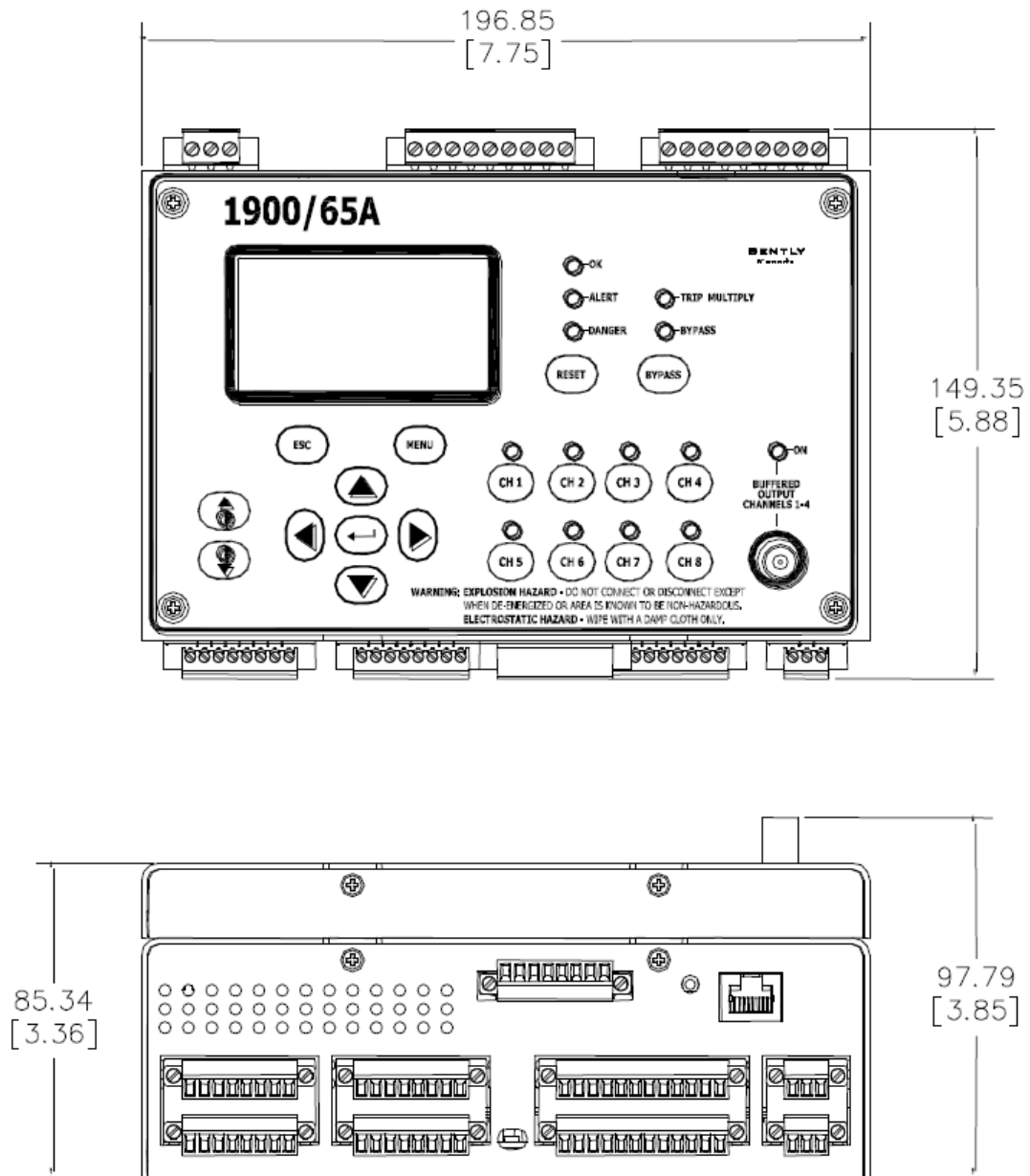


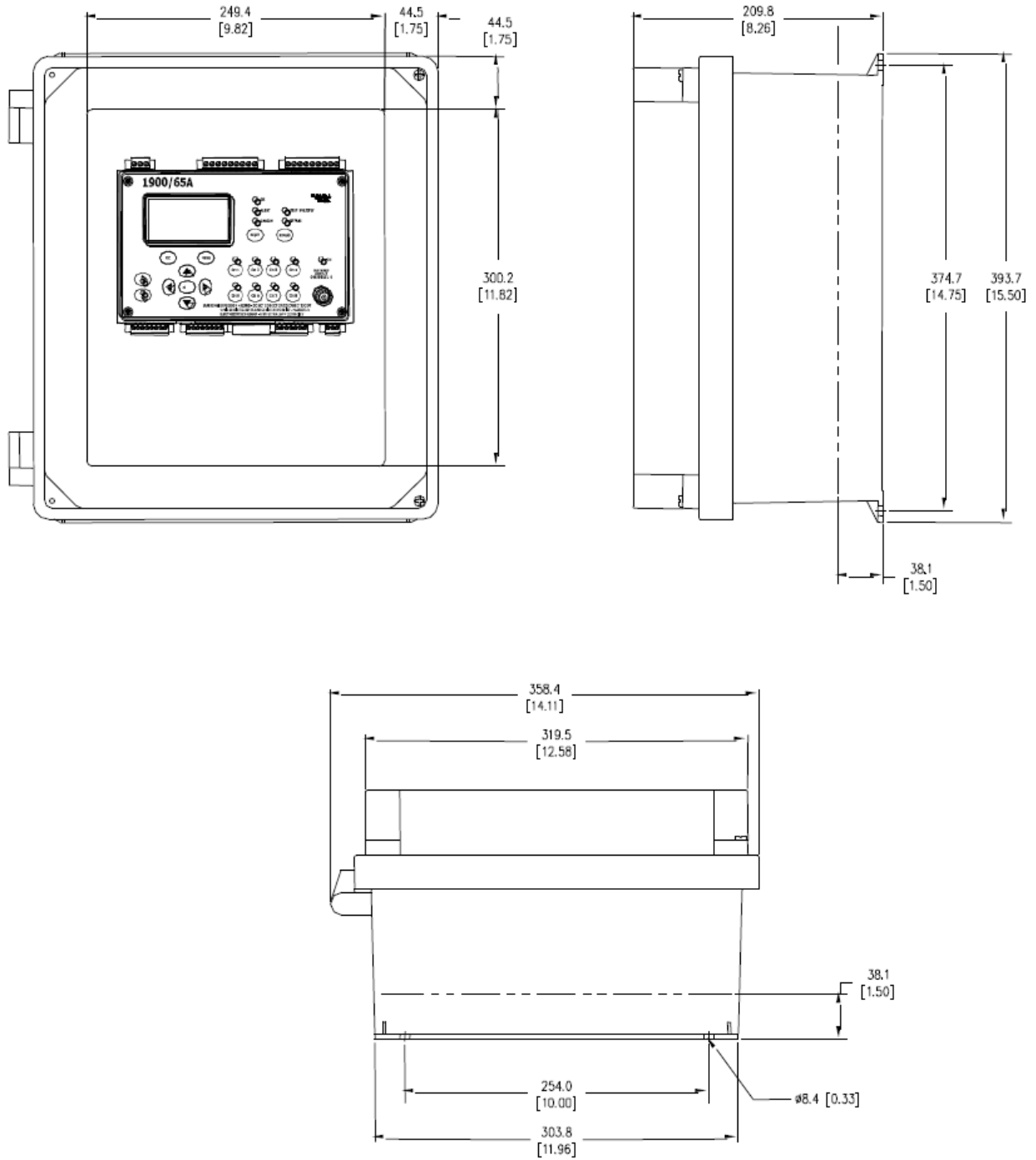
Figure 1: Monitor Module Dimensions



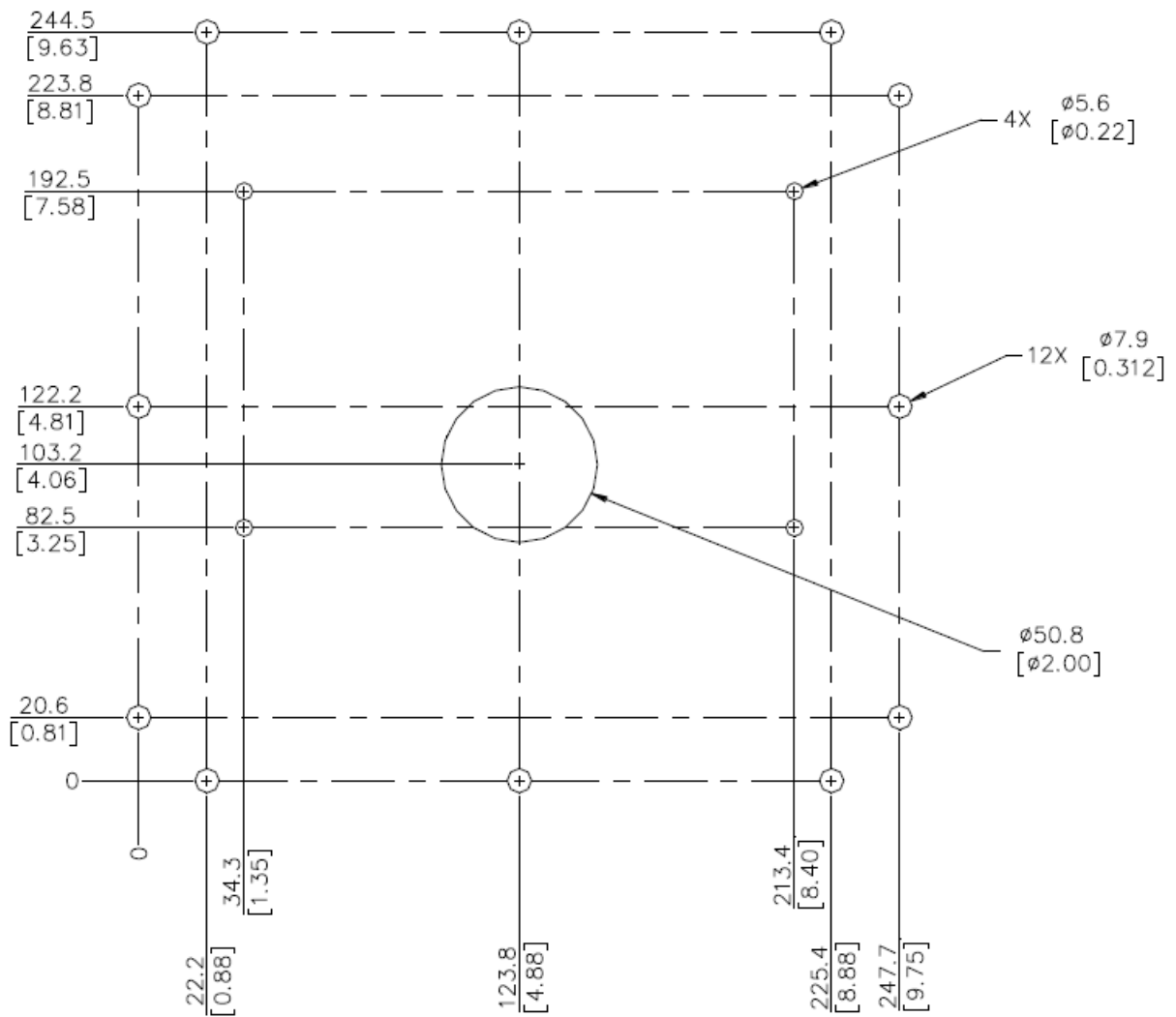
**Figure 2: Display Module Dimensions**



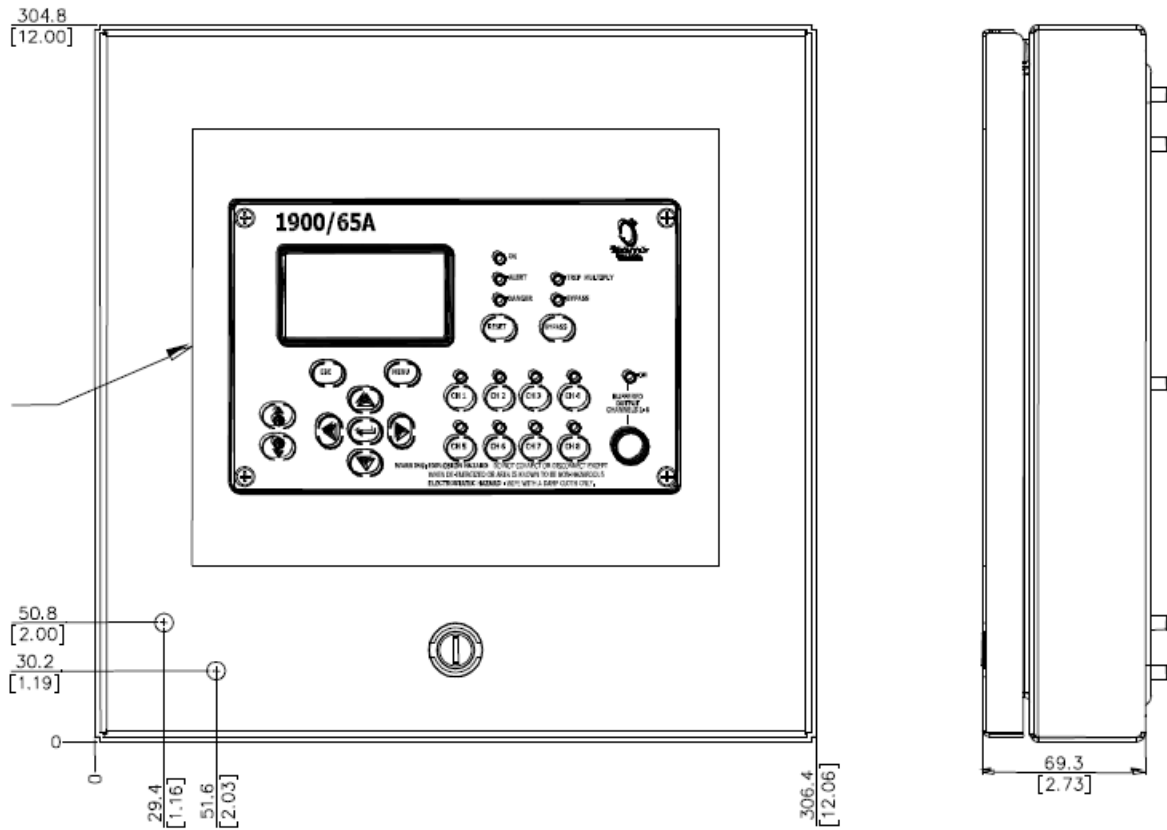
**Figure 3: Combined Dimensions**



**Figure 4: Weatherproof Housing Dimensions**

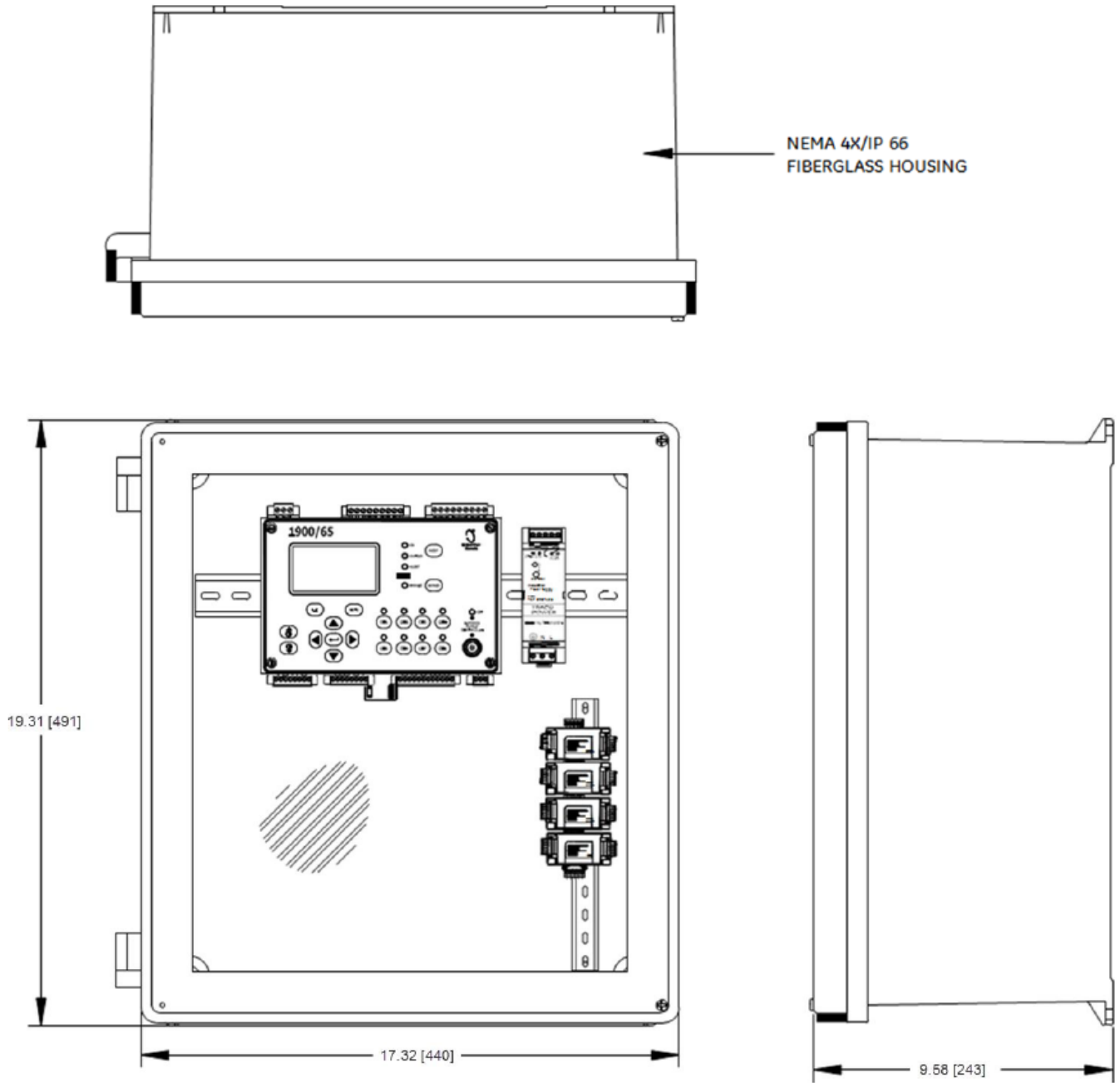


**Figure 5: Weatherproof Door Drill Pattern**



**Figure 6: Weatherproof Door Dimensions**





**Figure 7: ProTIM Housing Dimensions**

Copyright 2023 Baker Hughes Company. All rights reserved.



Bently Nevada, Proximito, System 1, Velomitor and Orbit Logo are registered trademarks of Bently Nevada, a Baker Hughes business, in the United States and other countries. The Baker Hughes logo is a trademark of Baker Hughes Company. All other product and company names are trademarks of their respective holders. Use of the trademarks does not imply any affiliation with or endorsement by the respective holders.

Baker Hughes provides this information on an "as is" basis for general information purposes. Baker Hughes does not make any representation as to the accuracy or completeness of the information and makes no warranties of any kind, specific, implied or oral, to the fullest extent permissible by law, including those of merchantability and fitness for a particular purpose or use. Baker Hughes hereby disclaims any and all liability for any direct, indirect, consequential or special damages, claims for lost profits, or third party claims arising from the use of the information, whether a claim is asserted in contract, tort, or otherwise. Baker Hughes reserves the right to make changes in specifications and features shown herein, or discontinue the product described at any time without notice or obligation. Contact your Baker Hughes representative for the most current information.

The information contained in this document is the property of Baker Hughes and its affiliates; and is subject to change without prior notice. It is being supplied as a service to our customers and may not be altered or its content repackaged without the express written consent of Baker Hughes. This product or associated products may be covered by one or more patents. See [Bentley.com/legal](https://www.bentley.com/legal).

1631 Bently Parkway South, Minden, Nevada USA 89423  
Phone: 1.775.782.3611 (US) or [Bentley.com/support](https://www.bentley.com/support)  
[Bentley.com](https://www.bentley.com)